

I²C-Multiplexer 4 Kanal (4 channel)

Zur Montage auf DIN-Schienen (Hutschienen) geeignet

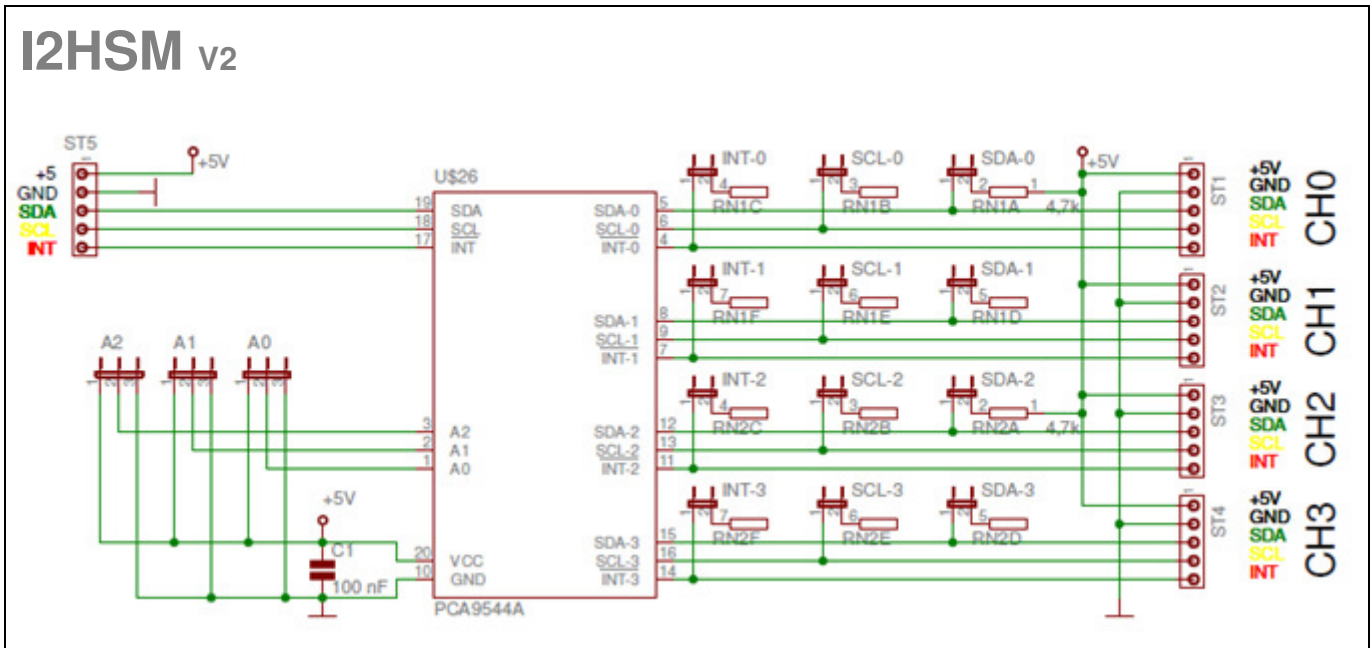

(download unter <http://www.horter.de/doku/>)

Adressen:

PCA 9544	
JP-A2 1 0	JP-A2 1 0
	224d
	226d
	228d
	230d
	232d
	234d
	236d
	238d

Bestückungsplan

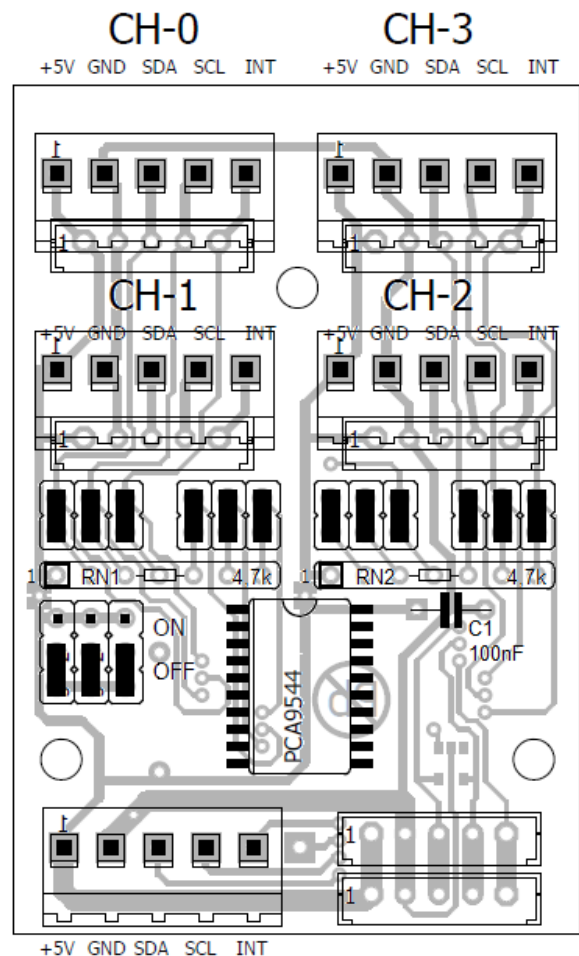

Stückliste:

Bauteil	Bezeichnung	Anz.
RN1, RN2	Widerstandsnetzwerk 6x 4,7k	2
C1	Keramik-Kondensator 100 nF	1
IC1	PCA 9544A SMD SO-20	1
JP1-15	Pfostenleiste 33 pol.	1
	Jumper	15
ST1-5	Anschlussklemme 5 pol.	5

Info:



Markierung beachten!

